

Installation, Operation, and Maintenance (IOM) Manual for Flanged Gate Valves

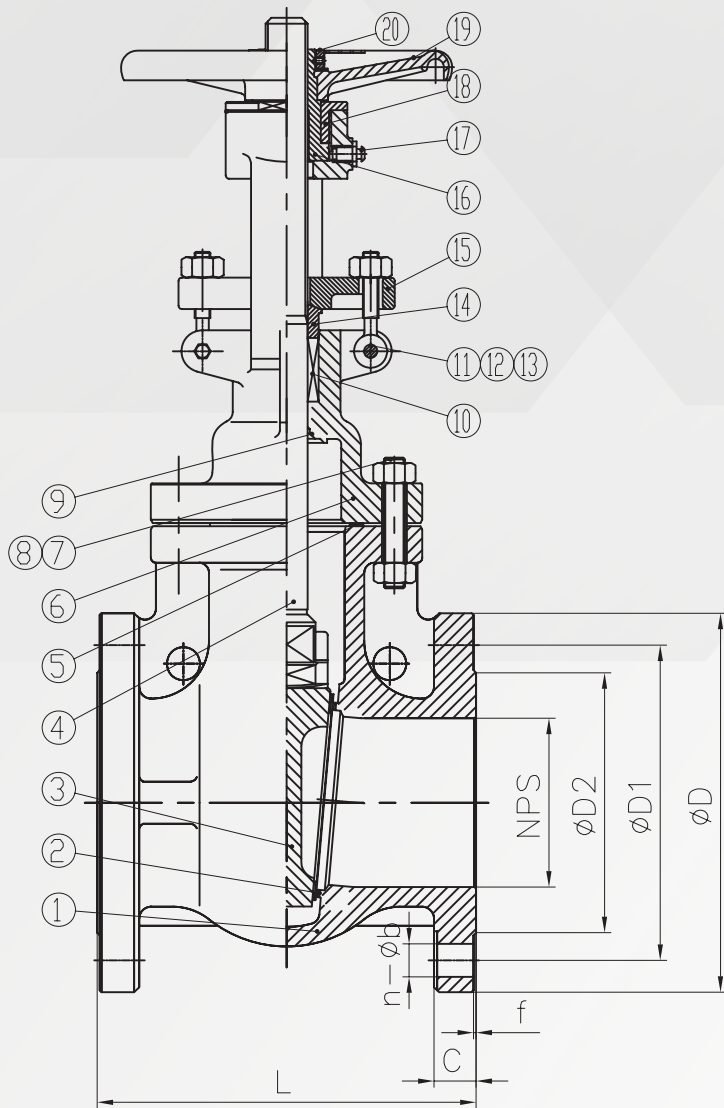

20	H. W. LOCK NUT
19	HANDWHEEL
18	RETAINING NUT
17	LUBRICATOR
16	STEM NUT
15	GLAND
14	BUSHING
13	GLAND NUT
12	GLAND BOLT
11	PIN
10	PACKING
9	BACKSEAT
8	NUT
7	STUD
6	BONNET
5	GASKET
4	STEM
3	WEDGE
2	SEAT RING
1	BODY

Refer to the diagram and parts list above for a detailed view of each component, assisting with installation, operation, and maintenance for optimal valve performance.



ANIX VALVE CO.LTD, Certified ISO 9001.

www.anixusa.com

Note: This manual provides guidance for the proper installation, operation, and maintenance of flanged gate valves to ensure efficient performance and long-lasting service. It includes general practices for safe usage, regular inspection, and potential troubleshooting. We are not liable for damages arising from its use. Consult a professional if you have specific concerns related to your application or environment. For additional assistance, contact your supplier or representative.

SAFETY INFORMATION

- The following safety precautions must be observed during installation, operation, and maintenance:
 - **Protective Gear:** Always wear appropriate safety equipment, including eye protection, gloves, and other necessary PPE.
 - **Pressure Precautions:** Never disassemble the valve while it's under pressure. Ensure upstream and downstream pressures are fully released.
 - **Temperature Caution:** Avoid direct contact with valve surfaces during high-temperature operations.
 - **Avoid Forceful Operation:** Handwheels and other components should not be operated with additional tools that increase torque.
 - **Stabilize Piping:** Support pipes on both sides of the valve to prevent stress, misalignment, or inefficiency.





ANIX VALVE CO.LTD, Certified ISO 9001.
www.anixusa.com

STORAGE AND PREPARATION

- **Temporary Storage**
 - Keep the valve wrapped and protected as received until installation.
 - Avoid removing protective covers or packaging until installation to prevent contamination.
 - If stored outdoors, place the valve in a way that avoids water accumulation.
- **Long-Term Storage**
 - Store valves in a dry, indoor environment.
 - Keep protective covers in place and apply a preservative coating if necessary.
 - Inspect periodically for signs of corrosion or damage.
- **Preparation for Installation**
 - Remove any temporary end protection and inspect for foreign materials.
 - Clean the valve body with compressed air as needed to ensure a clean flow path.
 - Ensure sufficient space around the valve for operation and maintenance access.

INSTALLATION

- **Flange Connection:** Confirm that flange faces are aligned and free from dirt or debris. Use appropriate gaskets and tighten bolts evenly in a cross-pattern for even gasket compression.
- **Positioning:** Valves can typically be installed in any orientation unless otherwise marked. Ensure the valve has adequate clearance for full operation.
- **Flow Direction:** If marked, align the valve with the indicated flow direction. Do not use gate valves for throttling, as this can cause premature wear.



ANIX VALVE CO.LTD, Certified ISO 9001.
www.anixusa.com

OPERATION

- Full Open/Closed Positions: Always operate the valve to a fully open or closed position to avoid wear on the seat and potential noise issues from partial opening.
- Lubrication: Periodically apply lubricant to the stem threads and handwheel mechanism for smooth operation.
- Avoid Excessive Force: Operate using only the handwheel provided to avoid excessive torque, which can damage internal components.

DISASSEMBLY

- Depressurize: Ensure that all upstream and downstream pressures are fully relieved before disassembly.
- Removing Components: Start by removing the bonnet bolts and carefully lift the bonnet assembly, including the stem and wedge.
- Handle Components Carefully: Remove gaskets and other components without damaging surfaces, especially the backseat and seating areas.

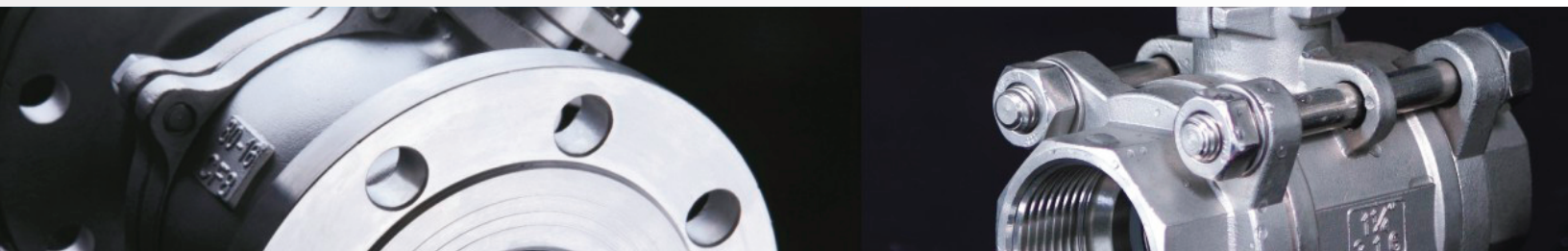



ANIX VALVE CO.LTD, Certified ISO 9001.
www.anixusa.com

MAINTENANCE

- **Routine Inspections**
 - Establish a maintenance schedule tailored to service conditions. Periodic inspection should include:
 - Seal Surface Check: Inspect for wear on the sealing surfaces. Repair or replace if necessary.
 - Thread and Stem Wear: Examine the stem and stem nut for signs of wear.
 - Gasket and Packing: Ensure gasket and packing materials are intact and effective. Replace if damaged or deteriorated.
- **Packing Replacement**
 - Relieve Pressure: Open the valve fully and confirm no internal pressure remains.
 - Packing Removal: Use care when removing old packing to avoid scratching the stem.
 - Install New Packing: Measure and install the correct amount of packing rings, compressing to ensure a tight seal.
 - Tighten: Secure the gland and eye nut without over-compression. Verify there are no leaks by operating the valve and monitoring the packing area.
- **Testing**
 - After reassembly or significant maintenance, perform a seat test to confirm a leak-tight seal under standard testing conditions.

